

FOURTEENTH SUNDAY AFTER PENTECOST
 Aug. 25, 2024 Lectionary Year B Proper 16
 Theme: Stewardship of Time, Talent and Treasure

360th Anniversary Celebration of the Mission and Ministry
 of St. Andrew Parish Church

6:30 a.m. HOLY EUCHARIST
 Old Testament 1 Kings 8: 22-30, 41 - 43 Milton Samuda
 Psalm 84 **Refrain:** (all sit) *“Happy are those who put their trust
 in the Lord.”*
 BCP page 483
 Epistle Ephesians 6:10 - 20 Hilary Phillips
 Gospel John 6: 56 - 69
 Prayer of Intercession BCP Form H page 120

8:00 a.m. SOLEMN EUCHARIST AND SERMON
 Processional 741 We love the place, O God
 Old Testament 1 Kings 8: 22-30, 41 - 43 Gervaise NcLeod
 Psalm 84 **Metric** (See Hymn 731) (all stand)
 Epistle Ephesians 6:10 - 20 Janet Shaw
 Acclamation Alle, alle alle-luia
 Gospel John 6:56 - 69
 Sermon Rev. Fr. Bertram Gayle
 The Creed BCP page 104
 Intercession BCP Form H page 120
 Offertory 348 The church’s one foundation
 During Communion 571, 296
 Recessional 439 Stand up, stand up for Jesus

Intentional Discipleship Prayer of the Diocese

Heavenly Father, we thank you that you have awakened Your Church to hear again, the call of our Saviour Jesus Christ to come to Him and learn from Him. Grant that as we say “Yes” to discipleship, your Holy Spirit will enable us so completely to commit all areas of our lives to His service, that in our personal, family and church lives, our work, recreational and social lives, we would act as Jesus would have acted if He were in our place; in His name and for His sake we pray. **Amen.**

Connecting to the streaming link for 8:00 a.m. Service

<https://www.facebook.com/sapcjamaica>.

The 8 a.m. service can also be viewed on Youtube.

There will be **NO** livestreaming of service on Sunday August 25, 2024. Livestreaming will resume on Sunday September 1, 2024.

Diocese of Jamaica & The Cayman Islands
ST. ANDREW PARISH CHURCH

Patron Saint Andrew The Apostle

Half - Way - Tree, Kingston 10. Telephone: 968-9366, 926-6692 , 926-0988

Office hours 9:00 a.m. - 5:00 p.m. Mon.- Fri.

Rectory: 927-0402 Curatage: 926-0800

E-mail: standrewch@cwjamaica.com

standrewparishch@gmail.com

Website: www.standrewparishchurch.com

Chapel of Ease:

St. Thomas - Majesty Gardens 10:30 a.m. and St. Clement’s - Kencot 10:30 a.m.



**INTENTION FOR THE YEAR:
 360th Anniversary**

CLERGY

Rector/Curate	The Very Revd. Canon Sirrano Kitson, D. Min.
Assistant Curate	Revd. Fr. Bertram Gayle
Supplementary Clergy	Revd. Fr. Claude Campbell
Church Army	Sister Andrea Taylor-Smith

Wardens

Rector’s Warden
 Mr. Dwayne McKenzie
 Email (dwayne_ja@yahoo.com)
 People’s Warden
 Norval West
 Email (ministry@norvalwest.com)

Administration

Office Administrator & Ops. Officer
 Administrative Assistant
 Mrs. Hortense James
 Verger - Miss Ann Morrison

The Rector is currently on leave.

We welcome all visitors to our worship and fellowship

Faith Formation and Christian Education

Did you know

“We can turn away from everything that keeps us from God and from living within God’s reign. You and I can repent and believe. But it is not always easy. To repent, or turn our lives in another direction, requires our will, our effort, and our faith as we call on God to supply the strength to turn toward God in all aspects of our living. And to believe in the unseen Companion who calls us to goodness and fills us with goodness is difficult when all those visible companions tend to discount the diving companionship promised to all who believe.”

Quote for reflection

“In repentance, I recognise my helplessness; by faith, I accept your mercy and experience your grace. By your grace, you free me from bondage to outward sin, and the power of inward sin is broken though not entirely destroyed.” — Norman Shawchuck & Rueben Job

Question for reflection

- Think about your journey of turning towards God's reign. What specific steps can you take to align your life more closely with God's intentions and teachings?

Electronic payment instruction JAMAICAN DOLLARS

Bank Name: NCB - Half-Way-Tree
Beneficiary Name: St. Andrew Parish Church
Beneficiary Account #: 301045077
Account Type: Current Account
If you encounter any difficulties with the transfer, contact your own bank.

Readings for September 1, 2024: Song of Solomon 2:8 - 13; Psalm 45:1 - 2, 7 - 10; James 1:17 - 27; Mark 7:1-8,14-15, 21-23.

Birthdays for this week: Monica Cameron, Angela Gregg, Valda Ormsby and Norval West 25/08, Rev. Seymour Hutchinson, Karlene Gordon and Hazel Thomas 26/08, Rev. Peter Clarke 27/08, Rev. Vinton Greene, Brian Goldson, Milinda Thompson, Shamar Brown and Pauline Boggis 28/08, Rev. Sydney Powell, Uroy Morrison and Amru Bromfield 29/08, Michelle Neita and Timothy Kitson 30/08, Albert Mighty, Carole Willis and Jason Jones 31/8.

Condolence is extended to Margaret Mais and family on the passing of her sister Juliet Gordon.

Fr. Ho Lung & friends presents Isaiah “Let there be Peace” National Arena, Sat. Oct. 5th at 7:30p.m & Sunday 6, at 2:00p.m & 6:30pm. Tickets are available at the Church Office.

Congratulations to all those who were successful in the CSEC and CAPE Examinations.

Interior Restoration - As we continue the interior painting project with a focus on the Nave, All Souls Chapel and the Choir Area, we would like to thank all who have contributed and encourage continued support to reach our target. Please continue to write the word PAINT on the envelope/cheque.

Mid-week services and Monday Bible Study are discontinued for the month of August. The Church will be open for prayer on Tuesdays and Fridays, beginning at 9am.

We express thanks to our members who continue to give sacrificially to ensure that the ministry and mission of the church are sustained as we continue to witness and minister in these challenging times.

Tuesday Charity will be on Tuesday the 3rd of September.

Rally of the Saints - Celebrating 360th Anniversary

WE PRAY ESPECIALLY FOR...

Percival Lynch (Priest) Elaine Baker Pearl Stern
June Spence Shirley Lee Christine McDonald
Leonard Green Monica Cameron Veta Coke
Hyacinth Elliott Flavia Dickson Hope Codlin

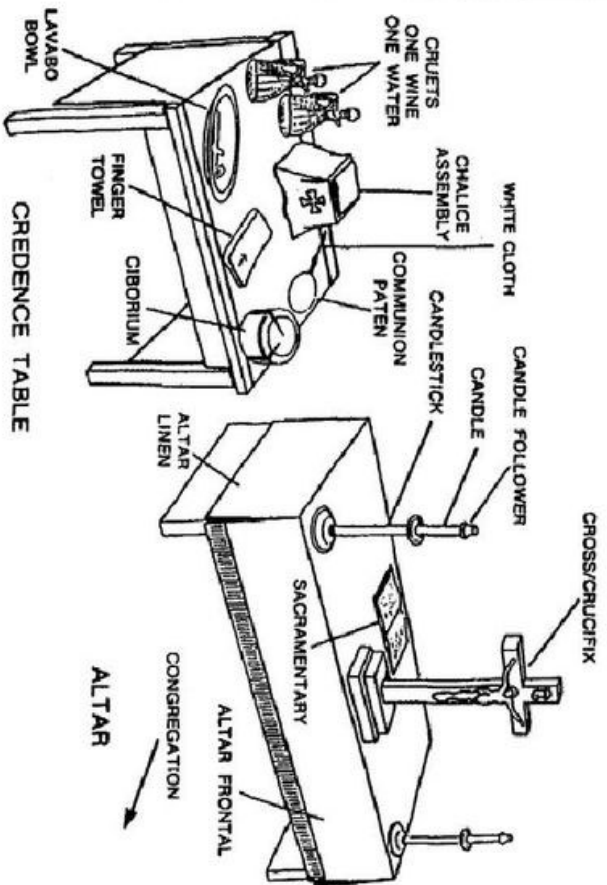

NOTE: There is no prescribed arrangement for the items on the credence table.

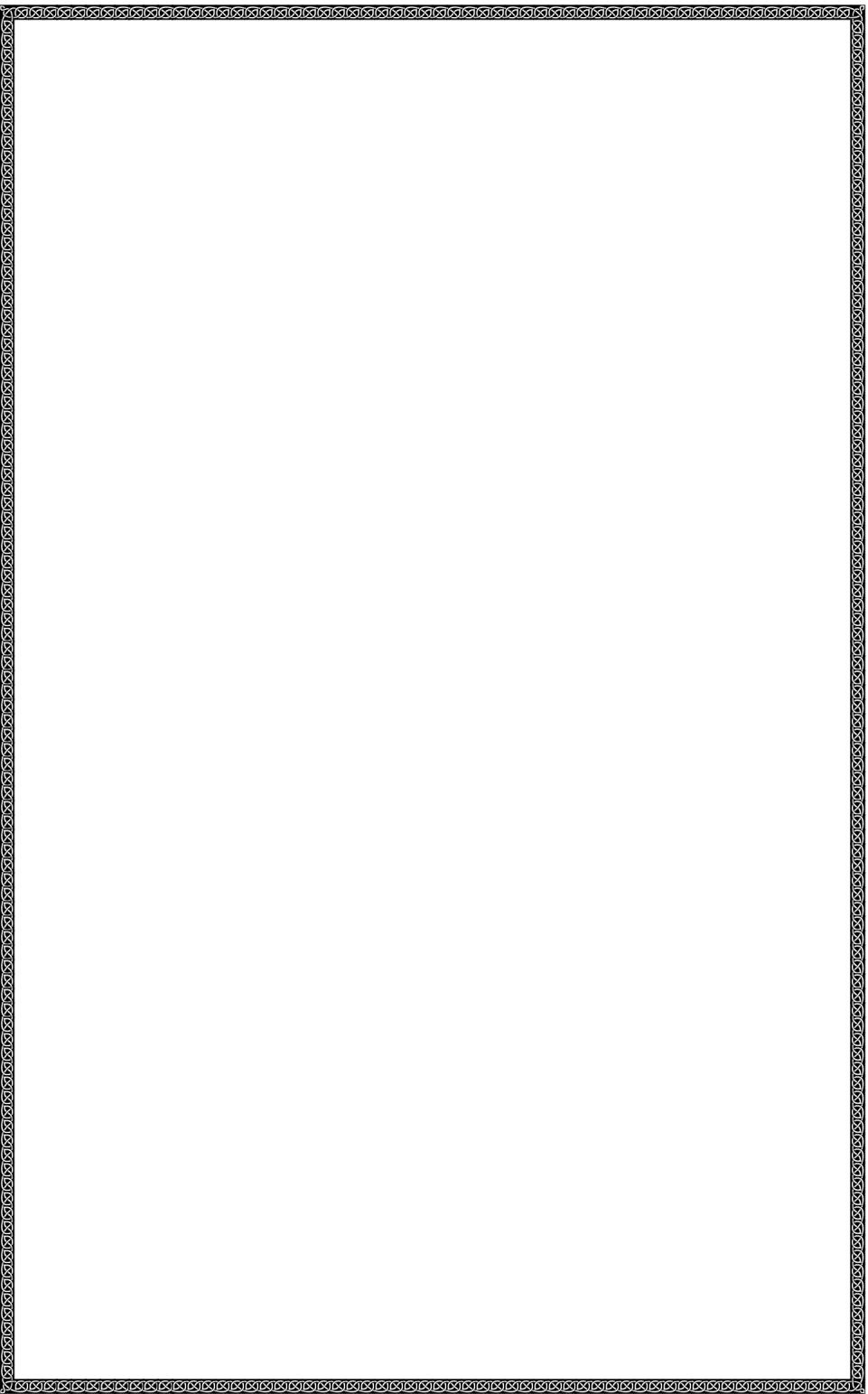

Liturgy for Sundays after Pentecost

Fourteenth Sunday after Pentecost.

August 25, 2024

President: The hour is coming, and now is, when the true worshippers will worship the Father in Spirit and in truth, for such the Father seeks to worship Him. (John 4:23)

President: + Praise the Father, Son and Holy Spirit Alleluia! Alleluia
All: Worthy of Praise forever and ever Alleluia! Alleluia

President: Alleluia. Worship the Lord in the beauty of Holiness
All: Come let us adore the Lord. Alleluia

President: Alleluia The Lord has shown forth His glory
All: Come let us glorify the Lord. Alleluia

President: Alleluia. Our God shall reign forever.
All: Let us praise and exalt the Lord forever. Amen. Alleluia

The Collect For Purity

Almighty God, to you all hearts are open, all desires known, and from you no secrets are hid: cleanse the thoughts of our hearts by the inspiration of your Holy Spirit, that we may perfectly love you, and worthily magnify your Holy Name, through Christ our Lord. *Amen.*

Gloria In Excelsis (Lisa Narcisse)

Glory to God in the highest, and on earth peace to men of goodwill. We praise you, we bless you, we adore you, we glorify you, we give you thanks, for your great glory.

O Lord God, Heavenly King, God the Father Almighty, Lord Jesus Christ, the only begotten Son. Lord God, Lamb of God, Son of the Father, You who take away the sin of the world: have mercy on us; You who take away the sin of the world, receive our prayer: You who sit at the right hand of the Father: mercy on us.

For you only are Holy; You only are the Lord: You only O Jesus Christ are most High, together with the Holy Spirit, In the glory of God the Father, in the glory of God the Father, in the glory of God the Father. Amen. Amen, Amen, Amen

The Collect for the Day

The Ministry of the Word

